

Titan Industrial Tools

1) Titan Flange Aligning Tool

Tool designed to align flange bolt holes without hammering and prying.

2) Titan Valve Wheel Latch Wrench

Used to increase leverage when turning valve wheels.

3) Titan Flange Key

Make to separate flanges without risking injury.

4) Titan Flange Spreader

Designed for safety in separating pipe and ring-type-joint flanges.

5) Titan Refinery Wrench

Combination pipe wrench and valve wrench designed for multiple uses.

Titan Tools are used in refineries, petrochemical, agrichemical and chemical plants, electrical and gas utility stations, pipe lines, oil fields, and various other industrial facilities.

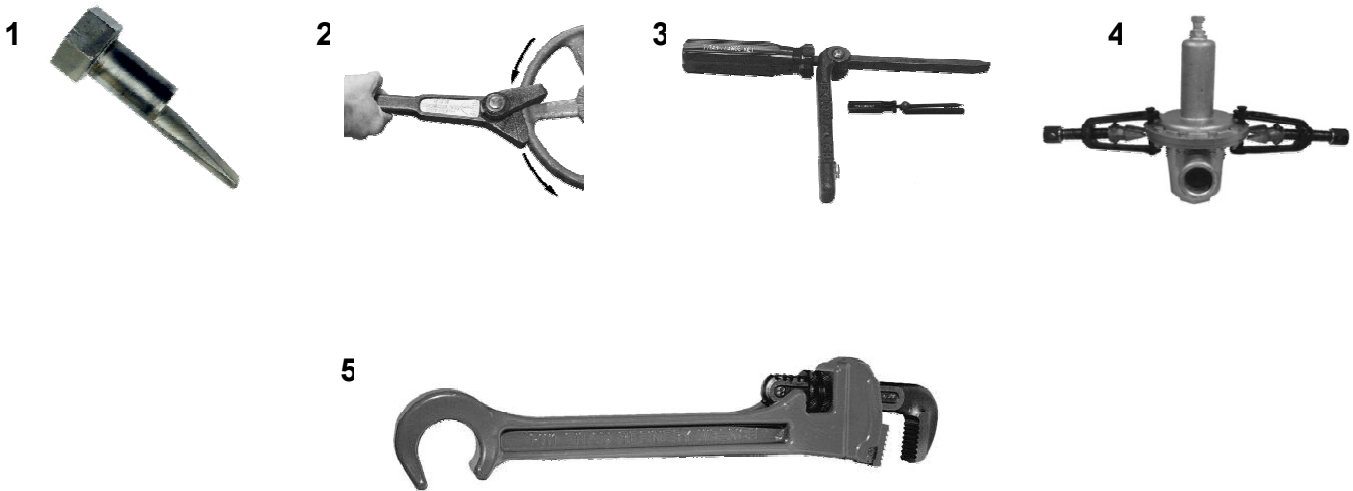

Call for volume pricing!

www.jcustom.com

1-800-226-5657

Phone: (225) 272-2210

Fax: (225) 272-2223

E-mail:

jcustomsupply@bellsouth.net

J Custom Supply, Inc.

10345 South Perdue

Baton Rouge, LA

70814

USA

Titan Flange Aligning Tool

TITAN FLANGE ALIGNING TOOLS are safe, fast, and effective. The tool's tapered shaft is a patented feature that eliminates the need for hammering and prying when lining up flange bolt holes.



1) Simply find a bolt hole that is aligned enough for the tapered shaft to fit through and turn.



3) If necessary, use a second tool and turn until the bolt holes are in alignment and insert flange bolts.

CATALOG NO.	BOLT HOLE SIZE	LENGTH	WEIGHT
FT00	3/8"	2-1/8"	1-1/4 ozs.
FT0	1/2"	2-3/8"	2-1/4 ozs.
FT01	5/8"	2-3/4"	4 ozs.
FT02	3/4"	3-1/4"	7 ozs.
FT03	7/8"	3-1/2"	11 ozs.
FT04	1"	4"	1 lb.
FT06	1-1/8"	5"	1-1/2 lbs.
FT08	1-1/4"	5-1/2"	2 lbs.
FT1012	1-3/8"	6-1/4"	2-7/8 lbs.
FT14	1-1/2"	6-1/2"	3-1/4 lbs.
FT16	1-5/8"	7-1/4"	4-1/8 lbs.
FT1820	1-3/4"	7-7/8"	4-3/4 lbs.
FT2426	2"	9"	6-5/8 lbs.
FT30	2-1/8"	12"	10-3/8 lbs.
FT34	2-3/8"	13-1/4"	13-1/8 lbs.
FT3642	2-5/8"	14"	16-7/8 lbs.

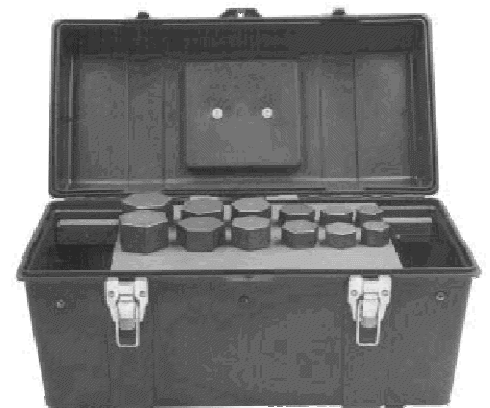
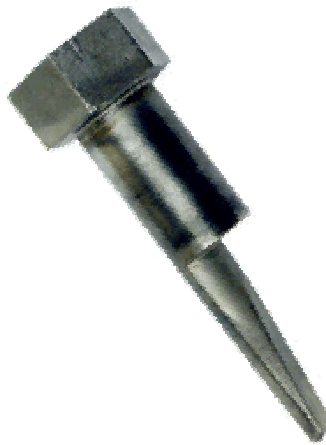

Shown Here – FTS212

TITAN FLANGE ALIGNING TOOLS are sold individually and in sets.

Titan Valve Wheel Latch Wrench

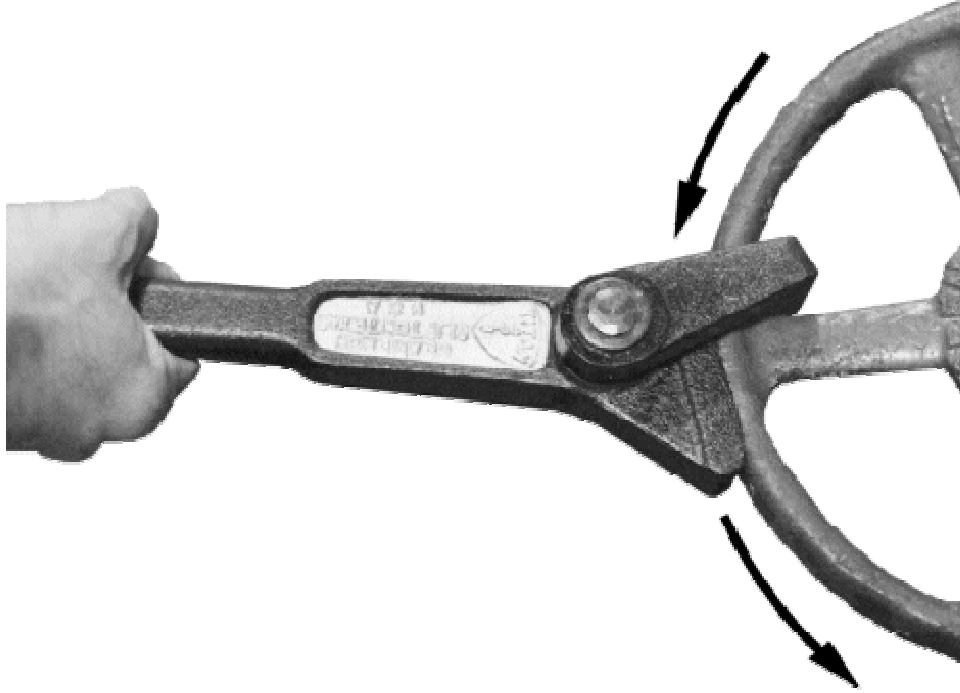

Catalog Number	Opening	Length	Weight
VWL1	1-3/16"	11-1/4"	3-1/2 LBS.

TO BE USED AS A HAND TOOL ONLY. DO NOT STRIKE, USE A "CHEATER", OR EXTEND HANDLE IN ANY WAY. FOLLOW OSHA, NATIONAL SAFETY COUNCIL, HAND TOOLS INSTITUTE, ETC., STANDARDS, SAFE PRACTICES & PROCEDURES.

www.jcustom.com
1-800-226-5657
Phone: (225) 272-2210
Fax: (225) 272-2223
E-mail:
jcustomsupply@bellsouth.net

J Custom
Supply
Inc

J Custom Supply, Inc.
10345 South Perdue
Baton Rouge, LA
70814
USA

Titan Flange Key



Use the TITAN FLANGE KEY to separate flanges instead of risking an injury because of the improper use of hand tools. The TITAN Flange Key has a blade made of heat-treated 5160 steel with the point sharpened to 3/32 of an inch. This, coupled with a hard plastic handle, allows the point of the blade to be easily driven between two flanges. The handle lever will not exceed 90° when opened, and a magnet holds it in place when closed to prevent the tool from opening while in a pocket or tool box.

<u>Catalog No.</u>	<u>Length</u>	<u>Weight</u>
FK100	11"	1-1/4 LBS.

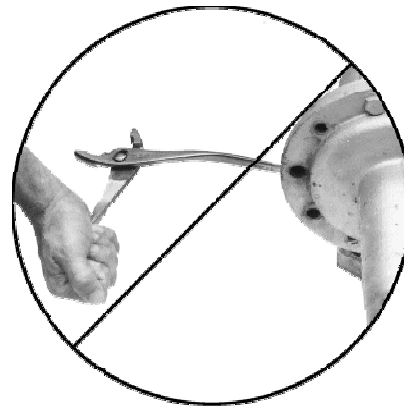
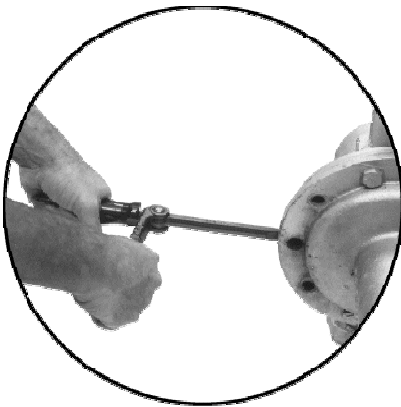

TO BE USED AS A HAND TOOL ONLY. DO NOT USE A "CHEATER", OR EXTEND HANDLE IN ANY WAY. FOLLOW OSHA, NATIONAL SAFETY COUNCIL, HAND TOOLS INSTITUTE, ETC., STANDARDS, SAFE PRACTICES & PROCEDURES.

www.jcustom.com
1-800-226-5657
Phone: (225) 272-2210
Fax: (225) 272-2223
E-mail:
jcustomsupply@bellsouth.net

J Custom
Supply
Inc

J Custom Supply, Inc.
10345 South Perdue
Baton Rouge, LA
70814
USA

Titan Flange Spreader



Catalog No.	Pin Spread Diameter*	Weight
N14	2-3/4" 5/8"	8 LBS.
N48	3-3/4" 3/4"	9 LBS.
N812	4-7/8" 7/8"	10 LBS.
N1216	6-1/8" 1"	15 LBS.
N1620	7-1/2" 1-1/8"	18 LBS.
N2024	9-1/8" 1-1/4"	20 LBS.

***Smaller pins available upon request.**

TITAN FLANGE SPREADERS have been carefully designed for safety in separating pipe and ring-type-joint flanges used in refineries, petrochemical, agrichemical and chemical plants, electrical and gas utility stations, pipe lines, oil fields, and various industrial facilities.

Key No.	Item Description	No. Required
1	Screw	1
2	Frame	1
3	U-Clip	1
4	Wedge	1
5	Flange Pin	1
6	Hitch Pin Clip	1

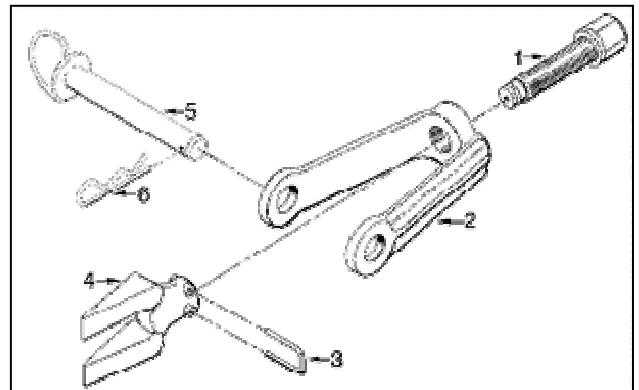

Titan Refinery Wrench



The TITAN REFINERY WRENCH is a combination pipe wrench / valve wheel wrench designed for multiple uses in the refining, petrochemical, and gas processing industries.

Catalog Number	Pipe Capacity	Wheel Wrench Opening	Length (Closed)	Weight
Steel				
RW1	1/8" – 1"	3/4"	10"	1-1/2 LBS.
RW2	1/8" – 1 1/2"	1/2"	10"	1-3/4 LBS.
Aluminum				
RW1AL	1/8" – 1"	3/4"	10"	3/4 LB.
RW2AL	1/8" – 1 1/2"	1/2"	10"	1 LB.

TO BE USED AS A HAND TOOL ONLY. DO NOT STRIKE, USE A "CHEATER", OR EXTEND HANDLE IN ANY WAY. ALWAYS PULL TOWARD BASE PAD. FOLLOW OSHA, NATIONAL SAFETY COUNCIL, HAND TOOLS INSTITUTE, ETC., STANDARDS, SAFE PRACTICES & PROCEDURES. DO NOT SUBJECT TOOL TO TEMPERATURES ABOVE 200 DEGREES F.

www.jcustom.com
1-800-226-5657
Phone: (225) 272-2210
Fax: (225) 272-2223
E-mail:
jcustomsupply@bellsouth.net

J Custom
Supply
Inc

J Custom Supply, Inc.
10345 South Perdue
Baton Rouge, LA
70814
USA